



The Advantage is CLEAR!

EXPERIENCE

With over 80 years of experience in the diesel engine business Kubota is proud to be the number one engine manufacturer of diesel engines below 100 HP. No other "small" engine comes close to offering the advantages that a Kubota engine brings. Trust the industry leader, use Kubota power.

RELIABLE AND DURABLE QUALITY

Kubota Corporation's Quality Inspection Facility is state-of-the-art and is dedicated to meet the high quality expectations of the Kubota name. Kubota engines will provide you with the tried and true quality needed for your generator applications.

EMISSIONS

The Engine Product Environmental Management Section at Kubota Corporation in Osaka, Japan takes all possible measures to ensure that the engines produced by Kubota meet the world's highest level of adaptability to pass future emission regulations. Kubota's BG Series meets all current emission levels for EPA, CARB, EU and MOC.

GLOBAL DISTRIBUTION NETWORK

Kubota engines are used all over the world. Kubota is committed to supporting its customers on a global basis by continuing to expand its distribution network world wide. Kubota provides all of its distributors with sales support and corporate sponsored service and product training in order to keep everyone up to date on the latest technical information.

Kubota Engine America Corporation
505 Scheller Road, Lincolnshire, IL 60069
phone: 847-955-2500 fax: 847-955-2501
www.kubotaengine.com

Kubota Canada, Ltd.
5900 14th Avenue, Markham, Ontario L3S 4K4
phone: 905-294-7477 fax: 905-294-1554
www.kubota.ca

Peace of mind . . . always!

Kubota's BG Series meets all of the current emission levels for EPA, CARB, EU and MOC.

TOUGH
Kubota
STUFF

BG Series
GENERATOR ENGINES



Kubota

**SPECIFICATION
GUIDE**

BG Series

GENERATOR ENGINES

Specifications

The Kubota BG Series engine line up is ideal for all of your generator applications such as light towers, welders and generators for industrial, standby and marine use. Kubota offers a full range of 60 Hz generator engines starting at 10 kW to 53 kW at 1800 rpm. Most of these engines are also available in 50 Hz from 8 kW to 35 kW.

Kubota's BG Series offers a solid gear train without the use of belts and a unique fly ball governor system to ensure stable output and regulation. Kubota's generator engine line up gives you a compact, high performance engine design for your generator application.

KUBOTA O5 SERIES - Diesel (13.1-20.2 HP)

Model	Emission Regulation	Cyl	Fuel Injection System	Aspiration System	Bore x Stroke mm (in)	Displace. L (cu. in)	Direction of Rotation (viewed from flywheel side)	Fuel Type No. 2 Diesel	Governor Type (Gov Droop)	Oil Pan Capacity L (gal)	Alternator Capacity V - A	Starter Capacity V - kW	Stand-by (SAE J1349)		Continuous (SAE J1349)		Fuel Consumption		Standard Flywheel	Standard Flywheel Housing	Length x Width x Height mm (in)	Dry Weight kg (lbs)
													60 Hz 1800 RPM kW (HP)	50 Hz 1500 RPM kW (HP)	60 Hz 1800 RPM kW (HP)	50 Hz 1500 RPM kW (HP)	1800 RPM (kg/kW-hr)	1500 RPM (kg/kW-hr)				
D1005-E3BG	Tier 4	3	IDI	NA	76 x 73.6 (2.99 x 2.90)	1.001 (61.08)	Counter Clockwise	Diesel	Mechanical (+/- 5%)	5.1 (1.34)	12-30	12-1.0	9.8 (13.1)	8.2 (11.0)	8.7 (11.7)	7.2 (9.7)	0.247	0.247	Short SAE 6.5"	Short SAE #5	551.3 x 393.8 x 605.1 (21.7 x 15.5 x 23.8)	109 (240.3)
D1105-E3BG	Tier 4	3	IDI	NA	78.0 x 78.4 (3.07 x 3.09)	1.123 (68.53)	Counter Clockwise	Diesel	Mechanical (+/- 5%)	5.1 (1.34)	12-30	12-1.0	11.5 (15.4)	9.5 (12.7)	10.1 (13.5)	8.4 (11.3)	0.247	0.247	Short SAE 6.5"	Short SAE #5	551.3 x 393.8 x 605.1 (21.7 x 15.5 x 23.8)	109 (240.3)
D1305-E3BG	Tier 4	3	IDI	NA	78.0 x 88.0 (3.07 x 3.46)	1.261 (76.95)	Counter Clockwise	Diesel	Mechanical (+/- 5%)	5.7 (1.51)	12-30	12-1.0	13.1 (17.6)	10.9 (14.6)	11.6 (15.6)	9.6 (12.9)	0.254	0.254	Short SAE 6.5"	Short SAE #5	551.3 x 394.3 x 590.1 (21.7 x 15.52 x 23.3)	111 (244.7)
V1505-E3BG	Tier 4	4	IDI	NA	78.0 x 78.4 (3.07 x 3.09)	1.498 (91.41)	Counter Clockwise	Diesel	Mechanical (+/- 5%)	6.7 (1.77)	12-30	12-1.2	15.1 (20.2)	12.5 (16.8)	13.4 (18.0)	11.1 (14.9)	0.247	0.247	Short SAE 6.5"	Short SAE #5	636.8 x 398 x 607.1 (25.1 x 15.7 x 23.9)	126 (277.8)

KUBOTA O3-M SERIES - Diesel (24.3-36.3 HP)

D1703-M-E3BG	Int. Tier 4	3	IDI	NA	87 x 92.4 (3.43 x 3.64)	1.647 (100.5)	Counter Clockwise	Diesel	Isochronous Electronic	5.6 (1.48)	12-40	12-1.4	18.1 (24.3)	15.0 (20.1)	15.1 (20.2)	12.8 (17.2)	0.235	0.233	Short SAE 7.5"	Short SAE #4	605.6 x 505.0 x 642.8 (23.9 x 19.9 x 25.3)	168 (370.4)
V2003-M-E3BG	Int. Tier 4 Stage IIIA	4	IDI	NA	83 x 92.4 (3.27 x 3.64)	1.999 (122.0)	Counter Clockwise	Diesel	Isochronous Electronic	7.6 (2.01)	12-40	12-1.4	21.8 (29.2)	18.1 (24.3)	18.2 (24.4)	15.5 (20.8)	0.235	0.233	Short SAE 7.5"	Short SAE #4	700.6 x 490.0 x 633.3 (27.6 x 19.3 x 25.0)	200 (440.9)
V2203-M-E3BG	Int. Tier 4 Stage IIIA	4	IDI	NA	87 x 92.4 (3.43 x 3.64)	2.197 (134.1)	Counter Clockwise	Diesel	Isochronous Electronic	7.6 (2.01)	12-40	12-1.4	24.2 (32.5)	20.1 (27.0)	20.2 (27.1)	17.2 (23.1)	0.235	0.233	Short SAE 7.5"	Short SAE #4	700.6 x 490.0 x 633.3 (27.6 x 19.3 x 25.0)	200 (440.9)
V2403-M-E3BG	Int. Tier 4 Stage IIIA	4	IDI	NA	87 x 102.4 (3.43 x 4.03)	2.434 (148.5)	Counter Clockwise	Diesel	Isochronous Electronic	7.6 (2.01)	12-40	12-2.0	26.5 (35.5)	22.0 (29.5)	22.1 (29.6)	18.8 (25.2)	0.235	0.233	Short SAE 7.5"	Short SAE #4	700.6 x 490.0 x 684.0 (27.6 x 19.3 x 27.0)	204 (449.7)
V2003-M-T-E3BG	Int. Tier 4 Stage IIIA	4	IDI	T	83 x 92.4 (3.27 x 3.64)	1.999 (122.0)	Counter Clockwise	Diesel	Isochronous Electronic	7.6 (2.01)	12-40	12-1.4	27.1 (36.3)	22.5 (30.2)	24.5 (32.9)	20.4 (27.4)	0.233	0.233	Short SAE 7.5"	Short SAE #4	700.6 x 490.0 x 674.0 (27.6 x 19.3 x 26.6)	204 (449.7)

KUBOTA V3 SERIES - Diesel (45.1-70.8 HP)

V3300-E3BG	Int. Tier 4 Stage IIIA	4	IDI	NA	98 x 110 (3.86 x 4.33)	3.318 (202.48)	Counter Clockwise	Diesel	Mechanical; Electronic Optional	13.2 (3.49)	12-45	12-2.5	33.6 (45.1)	27.5 (36.9)	30.6 (41.0)	25.0 (33.5)	0.244	0.243	Short SAE 11.5"	Short SAE #3	768.7 x 539 x 745.9 (30.3 x 21.2 x 29.4)	281 (619.5)
V3600-T-E3BG	Int. Tier 4 Stage I	4	IDI	T	98 x 120 (3.86 x 4.72)	3.620 (220.9)	Counter Clockwise	Diesel	Mechanical; Electronic Optional	13.2 (3.49)	12-45	12-3.0	43.1 (57.8)	35.3 (47.3)	39.2 (52.6)	32.1 (43.0)	0.246	0.243	Short SAE 11.5"	Short SAE #3	761.7 x 537.3 x 802.5 (30.0 x 21.2 x 31.6)	284 (626.1)
V3800DI-T-E3BG	Tier 3	4	DI	T	100 x 120 (3.94 x 4.72)	3.769 (230.0)	Counter Clockwise	Diesel	Isochronous Electronic	13.2 (3.49)	12-45	12-3.0	52.8 (70.8)	N/A	48 (64.4)	N/A	0.230	N/A	Short SAE 11.5"	Short SAE #3	768.6 x 543.5 x 797.0 (30.3 x 21.4 x 31.4)	280 (617.3)

*Specifications are subject to change without notice.

KUBOTA O5 SERIES - Diesel (13.1-20.2 HP)

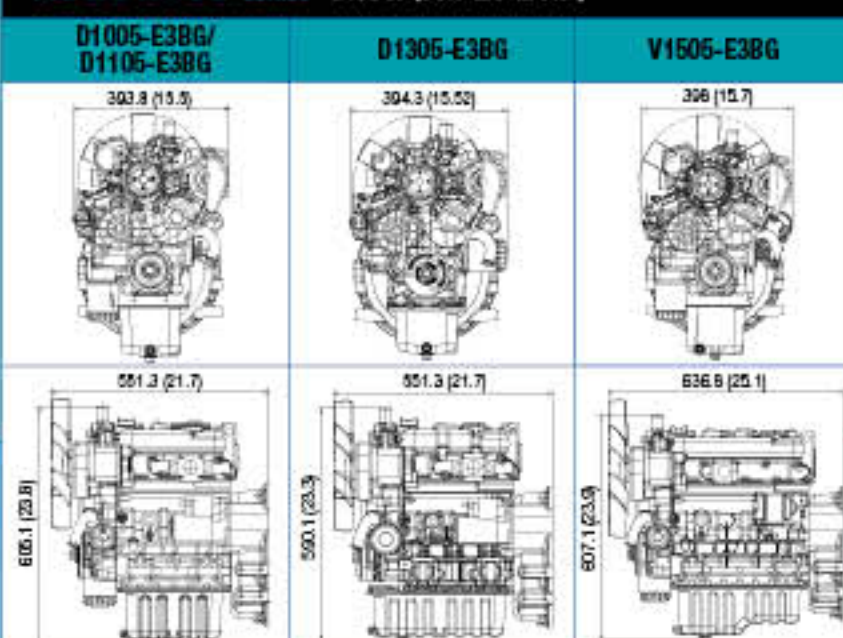

Model	Stand-by		kW Output at % Gen. Efficiency			Continuous Power		kW Output at % Gen. Efficiency		
	kW	HP	0.75	0.8	0.85	kW	HP	0.75	0.8	0.85
D1005-E3BG	9.8	13.1	7.4	7.8	8.3	8.7	11.7	6.5	7.0	7.4
D1105-E3BG	11.5	15.4	8.6	9.2	9.8	10.1	13.5	7.6	8.1	8.6
D1305-E3BG	13.1	17.6	9.8	10.5	11.1	11.6	15.6	8.7	9.3	9.9
V1505-E3BG	15.1	20.2	11.3	12.1	12.8	13.4	18	10.1	10.7	11.4

KUBOTA O3-M SERIES - Diesel (24.3-36.3 HP)

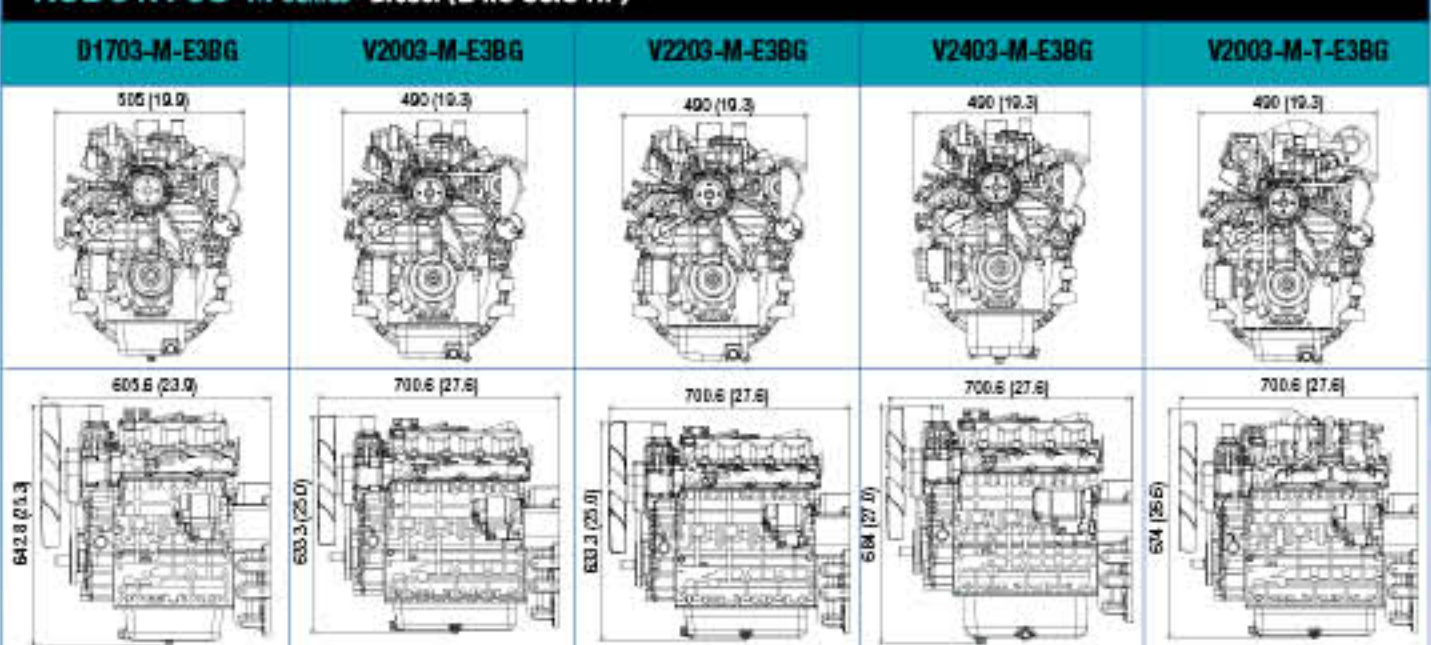

Model	Continuous Power		kW Output at % Gen. Efficiency			Continuous Power		kW Output at % Gen. Efficiency		
	kW	HP	0.75	0.8	0.85	kW	HP	0.75	0.8	0.85
D1703-M-E3BG	18.1	24.3	13.6	14.5	15.4	15.1	20.2	11.3	12.1	12.8
V2003-M-E3BG	21.8	29.2	16.4	17.4	18.5	18.2	24.4	13.7	14.6	15.5
V2203-M-E3BG	24.2	32.5	18.2	19.4	20.6	20.2	27.1	15.2	16.2	17.2
V2403-M-E3BG	26.5	35.5	19.9	21.2	22.5	22.1	29.6	16.6	17.7	18.8
V2003-M-T-E3BG	27.1	36.3	20.3	21.7	23.0	24.5	32.9	18.4	19.6	20.8

NOTE: For 50Hz electrical output please refer to allowable engine kW at 1500 rpm.

KUBOTA V3 SERIES - Diesel (45.1-70.8 HP)

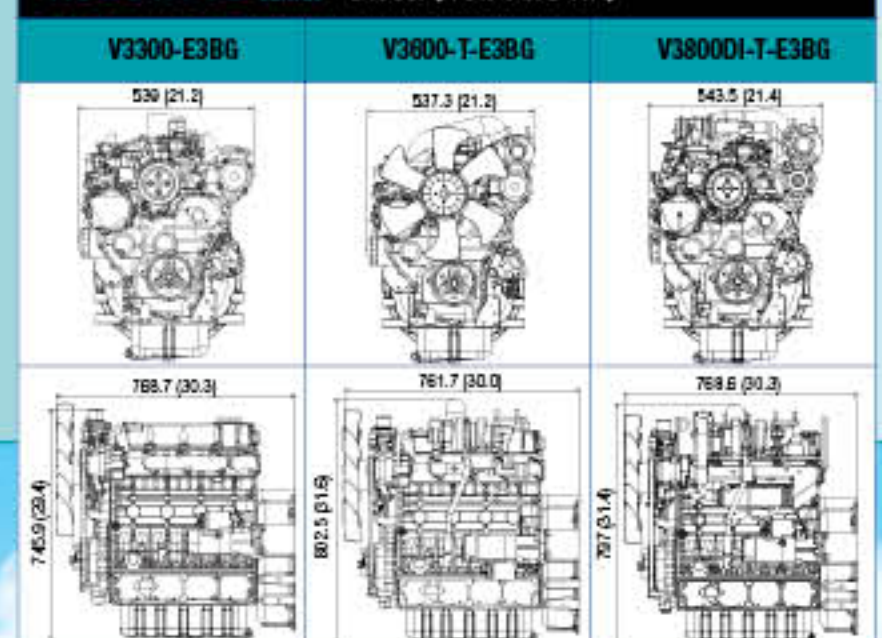

Model	Stand-by		kW Output at % Gen. Efficiency			Continuous Power		kW Output at % Gen. Efficiency		
	kW	HP	0.75	0.8	0.85	kW	HP	0.75	0.8	0.85
V3300-E3BG	33.6	45.1	25.2	26.9	28.6	30.6	41.0	23.0	24.5	26.0
V3600-T-E3BG	43.1	57.8	32.3	34.5	36.6	39.2	52.6	29.4	24.5	33.3
V3800DI-T-E3BG	52.8	70.8	39.6	42.2	44.9	48.0	64.4	36.0	38.4	40.8