

Kubota

Bulletin No : OEM-21-001
 Date : Feb. 26, 2021
 Replace : OEM-20-008
 Ref.PB No :

(Authorized by)

K. HIGUCHI

Service Training Gr.
 Engine Service Dept.

SUBJECT :
STORAGE CONDITIONS AND
OPERATION CHECK OF LONG-TERM
STORAGE ENGINES
(REVISED)

MODEL : ALL MECHANICAL & ELECTRICAL KUBOTA ENGINES

SERIAL No. AFFECTED : ALL

COUNTRY AFFECTED : ALL COUNTRIES

REASON FOR ISSUE :

This SB has been modified and reissued for use with all engines. It is based on SB No. (OEM-20-008) "STORAGE CONDITIONS AND OPERATION CHECK OF LONG-TERM STORAGE ENGINES" issued 2020 November, but includes additional information on horizontal diesel engines (OC/AC Series and EA Series engines).

WARRANTY INFORMATION

- Mandatory Campaign : Allowable Man-hours ;
- Technical Bulletin : Allowable Man-hours ;
- Quality Related Information

SERVICE INFORMATION

S
E
R
V
I
C
E

B
U
L
L
E
T
I
N

KBT Order No. : NA

STORAGE CONDITIONS AND OPERATION CHECK OF LONG-TERM STORAGE ENGINES

All Kubota engines (mechanical diesel & gasoline/gas engines and electrical diesel (common rail type) & gasoline/gas engines) manufactured and inspected at Kubota factories are subjected to anticorrosion treatment such as filling and coating of rust preventatives and sealing of intake / exhaust manifold ports.

However, there may be a possibility of corrosion (s) due to improper storage conditions at customers' site and / or malfunction of key components (e.g. fuel injection pump) after "One (1) year (*)" of long storage due to degradation of residual fuel inside the engine.

In order to avoid such troubles, please follow the conditions listed below for engine storage and proper inspections prior to engines usage.

(*OC/AC Series engines: The information here applies to long-term inventory (six months or greater) engines.)

I. ENGINE STORAGE ENVIRONMENTS (ALL KUBOTA ENGINES)

Select a location such as the following for storage.

1. Keep engines inside the building in order to avoid direct contact with rain.
2. Keep engines in dry conditions with proper ventilation.
3. Keep engines away from direct exposure to sunlight.
4. Keep engines away from extreme thermal conditions.
5. Keep engines away from sea-breeze.
6. Keep engines away from wildlife (birds, rats, insects etc).

II. ENGINE STORAGE CONDITIONS (ALL KUBOTA ENGINES)

1. Keep engines within adequate packaging and place on a hard, flat surface.
2. Tighten up the oil fill cap well in order to seal the engine.
3. Insert the oil gauge adequately in order to seal the engine.
4. Cover all ports such as inlet manifold, exhaust manifold, breather pipe, fuel inlet locations, aftertreatment device outlet, sensor/ECU couplers, etc. in order to avoid air and dust ingress.
5. Apply plastic bag over the engine in order to avoid direct exposure to rain, air and dust.
6. When stopping or storing an LPG specification engine for a long period of time, drain gas prior to stopping operation to prevent sulfur-containing residual gas from damaging the motor.

III. INSPECTION BEFORE THE USAGE OF LONG-TERM STORAGE ENGINES

Please conduct below inspection before using engines which have been stored for more than One (1) year.

1. VISUAL CHECK (ALL KUBOTA ENGINES)

- 1) Check there is no rusting on the surface of the engines.
- 2) Check there are no discolorations and cracks of the cooling fan and/or degradations of the fan belt.
Replace with new parts if necessary.
- 3) Check there are no breakages of exterior parts. Replace with new parts if necessary.
- 4) Check there are no signs of water, fuel and oil leakage. In case of any signs of leakage, identify the cause and make necessary repair.

2. OPERATIONAL CHECK OF FUEL INJECTION PUMP (MECHANICAL DIESEL ENGINES)

Fuel on the surface of the Plunger and the Barrel of Fuel Injection Pump work as anticorrosion material and lubricant. If the engines are kept for a long period in unchanged conditions, the Plunger and the Barrel of the Fuel Injection Pump may seize due to degradation and/or oxidation of the fuel. If an attempt is made to start the engine with a seized Fuel Injection Pump, the engine may have starting failure and/or overrun as a result of uncontrollable engine speed. Follow below instruction and check there is no seizure of the Plunger of Fuel Injection Pump before the use of the long-term storage engine.

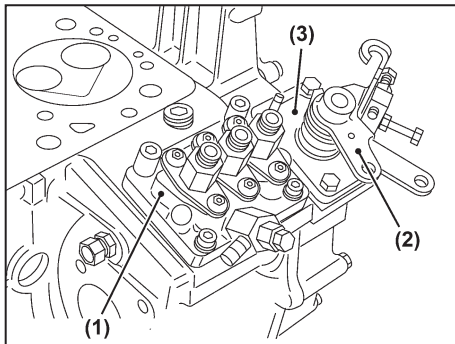

NSM SERIES (MECHANICAL DIESEL ENGINES)

1. Refer to "Disassembling and Assembling of Fuel Injection Pump" section of Work Shop Manual.
2. Check the Stop Lever (2) moves smoothly by hand (i.e. Control Rack of Fuel Injection Pump (1) moves smoothly).
3. In case the Fuel Injection Pump (1) is seizing, disassemble the Fuel Injection Pump (1) from the engine for repair or replace with the new Pump if necessary.

- (1) Fuel Injection Pump
- (2) Stop Lever
- (3) Speed Control Plate

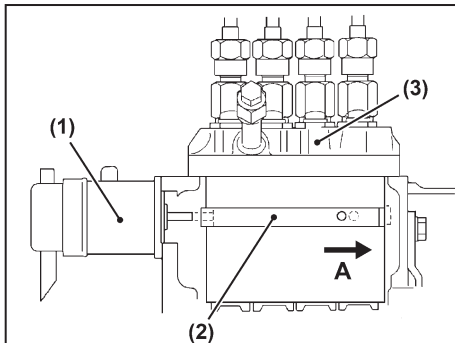

05 SERIES (MECHANICAL DIESEL ENGINES)

1. Refer to "Disassembling and Assembling of Fuel Injection Pump" section of Work Shop Manual.
2. Disassemble the Engine Stop Solenoid (1) and the Speed Control Plate from the engine.
3. Check the Control Rack (2) of the Fuel Injection Pump (3) moves smoothly by hand.
4. In case the Fuel Injection Pump (3) is seizing, disassemble the Fuel Injection Pump (3) from the engine for repair or replace with the new Pump if necessary.

- (1) Engine Stop Solenoid
- (2) Control Rack
- (3) Fuel Injection Pump
- (4) Start Spring
- (5) Rack Pin
- (6) Fork Lever

A : To Stop

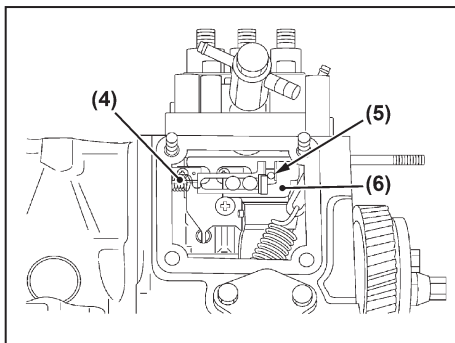

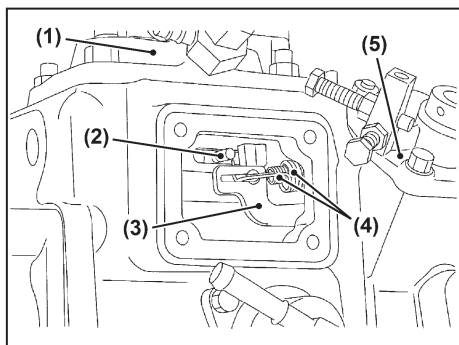

03 SERIES (APPLIED ONLY TO MECHANICAL DIESEL ENGINES)

1. Refer to "Disassembling and Assembling of Fuel Injection Pump" section of Work Shop Manual.
2. Disassemble the Engine Stop Solenoid and the Cover from the engine.
3. Check the Control Rack (2) of the Fuel Injection Pump (1) moves smoothly by hand.
4. In case the Fuel Injection Pump (1) is seizing, disassemble the Fuel Injection Pump (1) from the engine for repair or replace with the new Pump if necessary.

- | | |
|-------------------------|-------------------------|
| (1) Fuel Injection Pump | (4) Governor Spring |
| (2) Control Rack | (5) Speed Control Plate |
| (3) Fork Lever | |

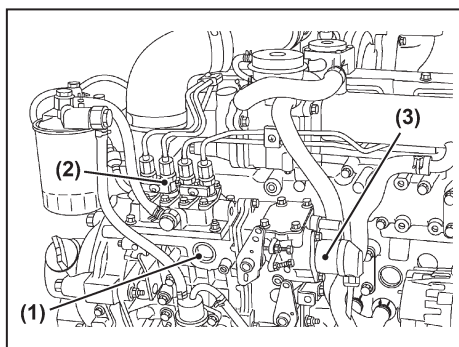

07 & V3 SERIES (APPLIED ONLY TO MECHANICAL DIESEL ENGINES)

1. Refer to "Disassembling and Assembling of Fuel Injection Pump" section of Work Shop Manual.
2. Disassemble the Engine Stop Solenoid (3) and the Cover Plug (1) from the engine.
3. Check the Connecting Rod (4) of the Fuel Injection Pump (2) moves smoothly by hand.
4. In case the Fuel Injection Pump (2) is seizing, disassemble the Fuel Injection Pump (2) from the engine for repair or replace with the new Pump if necessary.

- | | |
|--------------------------|--|
| (1) Cover Plug | |
| (2) Fuel Injection Pump | |
| (3) Engine Stop Solenoid | |
| (4) Connecting Rod | |
| (5) Control Rack | |

[A] After the cover plug (1) is removed

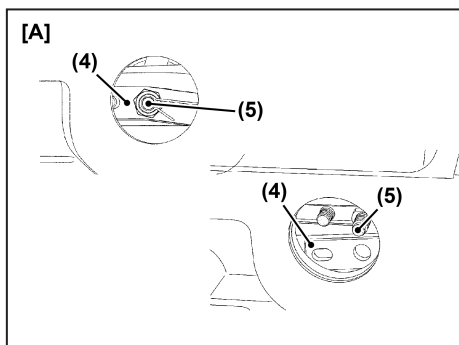

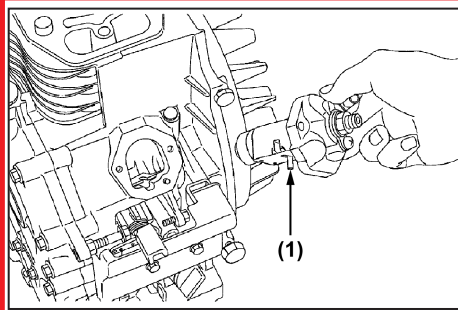

OC/AC series

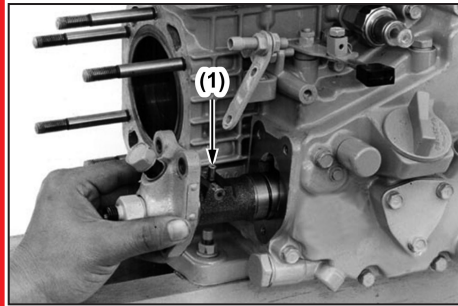

EA series

OC/AC SERIES AND HORIZONTAL DIESEL ENGINES (EA SERIES)

1. Refer to "Disassembling and Assembling of Fuel Injection Pump" section of Work Shop Manual.
2. Follow the instructions in the Workshop Manual to confirm that the injection pump can be removed.
3. Use your finger to confirm that the control rack pin (1) can be moved smoothly within the range of movement.
4. If the fuel injection pump is stuck.
Either have it repaired at a designated service shop or replace it with a new fuel injection pump.

(1) Control Rack Pin

3. OPERATIONAL CHECK OF THE ROTATING PARTS (ALL KUBOTA ENGINES)

Rotate the Flywheel by hand and check the followings.

- 1) No abnormal noises.
- 2) Air compression inside each cylinder.

4. OPERATION AFTER LONG-TERM STORAGE (ALL KUBOTA ENGINES)

- 1) Bleed air before starting operation, including the injection pump.
- 2) Carry out sufficient warm-up operation while idling.